

TS408 MY-8

50 ML CARTRIDGE DISPENSER

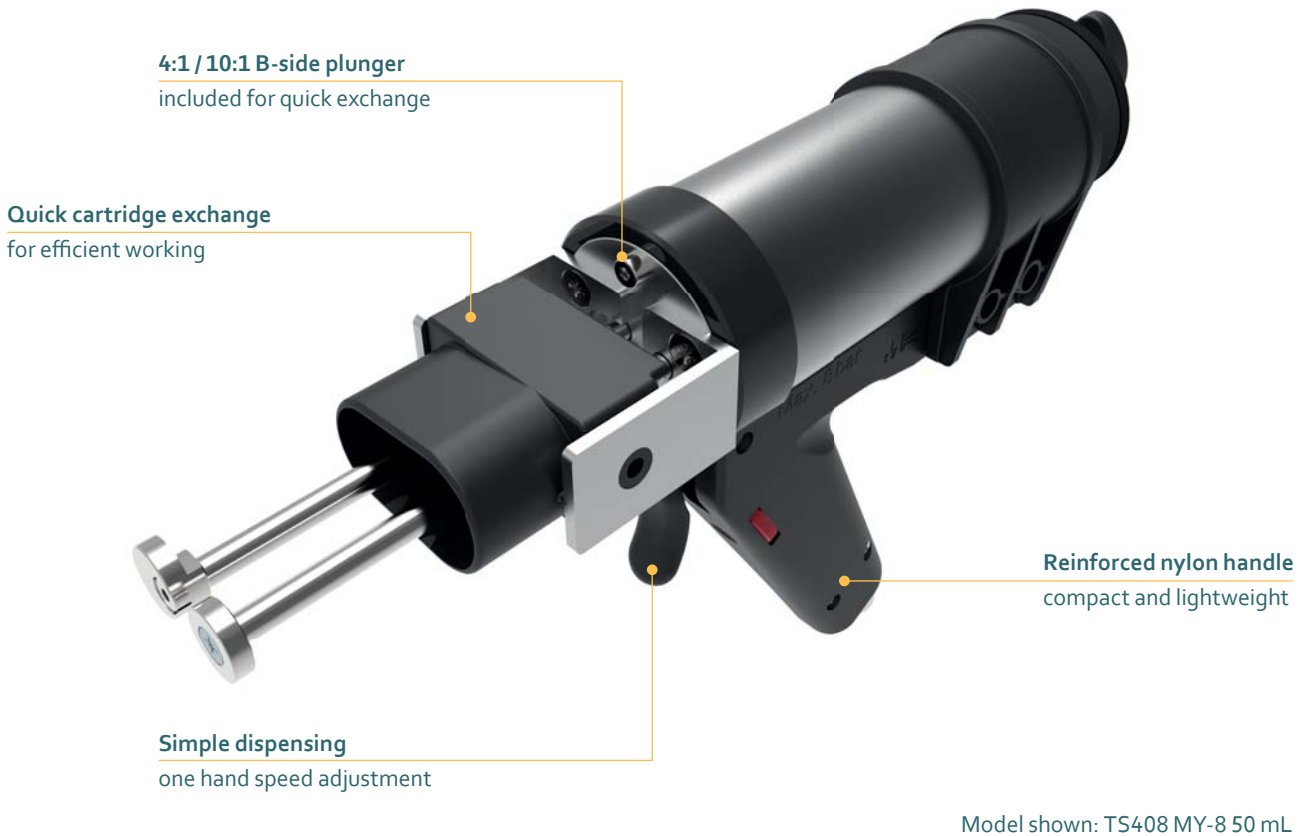

FEATURES

- Quick cartridge exchange
- One hand pressure adjustment
- Anti-drip function
- Reinforced nylon handle
- Customization possible

BENEFITS

- For efficient working
- Simple dispensing, effective working
- Clean application
- Compact and lightweight
- Customer labelling

APPLICATIONS



Bonding

PRODUCT BY RANGE



THE TS408 MY-8 2-COMPONENT PNEUMATIC DISPENSERS ONE-HANDED PRESSURE ADJUSTMENT ALLOWS FOR SIMPLE EFFECTIVE OPERATION WHILE THE QUICK CARTRIDGE EXCHANGE OFFERS EFFICIENT WORKING ACROSS ALL YOUR APPLICATIONS.

SPECIFICATIONS

- Lightweight: 0.73 kg / 1.6 lbs
- Dispenser Length: 303 mm / 11.9 in
- Maximum Thrust: 1.3 kN
- Maximum Pneumatic Pressure: 8 bar / 116 psi
- Air Consumption: 40 litres/min
- Handle Material: Reinforced Nylon
- Cartridge Holder Material: Reinforced Nylon
- Cartridge Capacity: 50 mL (1.8 oz), 75 mL (2.7 oz)
- Cartridge Ratios: 1:1, 2:1, 4:1, 10:1
- Viscosity: High
- Standard Color: Black
- Customized versions on demand

DIMENSIONS

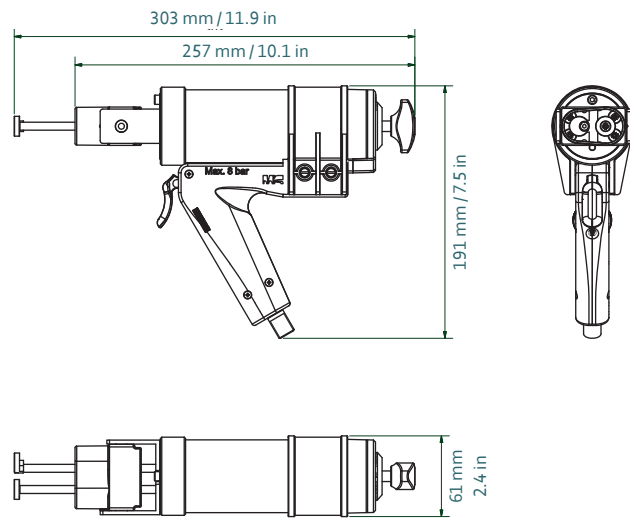

Part number	Article number	Packaging
DP2K 050-MR-130-001	151780 (50 mL)	1 per Box

MATCHING MIXPAC™ SIDE-BY-SIDE CARTRIDGES



A-System
50 mL / 1:1 PP/PA



B-System
50 mL / 1:1 PP/PA



A-System
50 mL / 2:1 PP/PA



B-System
50 mL / 2:1 PP/PA



A-System
50 mL / 4:1 PP/PA



A-System
50 mL / 10:1 PP/PA

COMPATIBLE CARTRIDGES

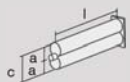

Rectangular Flange Cartridge
50 mL / 1:1 PP/PBT

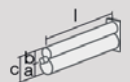

Rectangular Flange Cartridge
50 mL / 2:1 PP/PBT

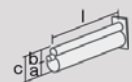

Rectangular Flange Cartridge
50 mL / 4:1 PP/PBT

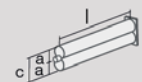

Rectangular Flange Cartridge
50 mL / 10:1 PP/PBT

	1:1	mm	inch	2:1	mm	inch	4:1	mm	inch	10:1	mm	inch
l		99.7	3.93	l	108.5	4.27	l	108.5	4.27	l	102.0	4.02
a		Ø 21.0	Ø 0.83	a	Ø 25.0	Ø 0.89	a	Ø 25.0	Ø 0.89	a	Ø 30.0	Ø 1.18
c		46.0	1.81	b	Ø 18.0	Ø 0.71	b	Ø 13.0	Ø 0.51	b	Ø 10.8	Ø 0.43
				c	46.0	1.81	c	46.0	1.81	c	44.0	1.73

CONVERSION KITS

MATCHING ACCESSORIES