

T22 XP

400/600 ML SACHET DISPENSER



Balanced dispenser
for precise working

One hand speed adjustment
dispensing made simple

Reinforced nylon handle
for comfortable use

Model shown: T22 XP 600 mL

FEATURES

- Reinforced nylon handle
- One hand pressure adjustment
- Balanced dispenser
- Forward air release
- Warranty up to 2 years

BENEFITS

- For comfortable use
- Easy simple dispensing
- For precise working
- Fast, reliable and easy handling
- Gives you long worry free performance

APPLICATIONS

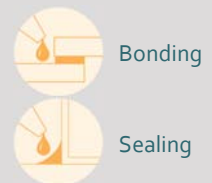

Bonding

Sealing

PRODUCT BY RANGE

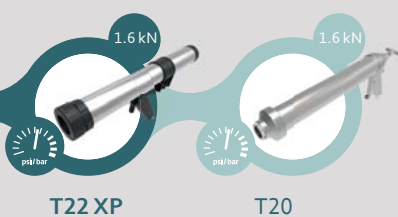

T22 XP

T20

THE T22 XP 1-COMPONENT PNEUMATIC DISPENSER IS DESIGNED FOR USE WITH LOW TO MEDIUM VISCOSITY SEALANTS AND ADHESIVES, WHILE THE FORWARD AIR RELEASE MAKES FOR EASY OPERATION.

SPECIFICATIONS

- Lightweight: 0.98 kg / 2.2 lbs
- Frame Length: 401 mm / 15.8 in
- Maximum Thrust: 1.6 kN
- Maximum Pneumatic Pressure: 8 bar / 116 psi
- Air Consumption: 40 litres/min
- Handle Material: Reinforced Nylon
- Barrel Material: Aluminum
- Tool Component Approvals: CE
- Sachet Capacity: 400 mL, 600 mL
- Standard Color: Black/Grey
- Customized versions on demand

DIMENSIONS

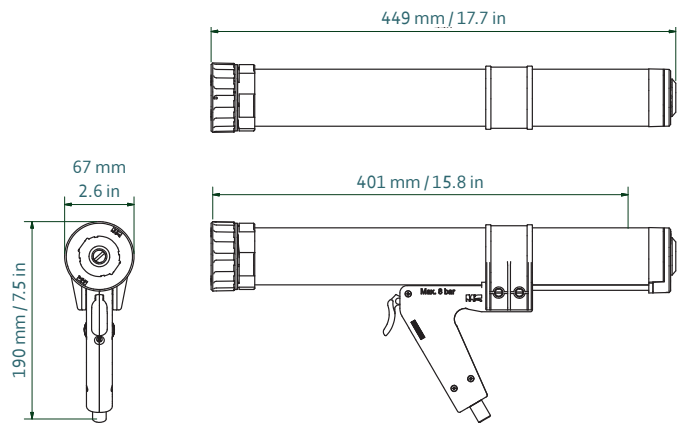

Part number	Article number	Packaging
DP1K 600-sa-160-001	151777	1 per box, 10 per master carton

MATCHING MIXPAC™ CARTRIDGES

COMPATIBLE CARTRIDGES AND SACHETS

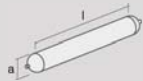

Sachet
400 mL

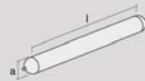

Sachet
600 mL

	mm	inch
l	258.0	10.16
a	Ø 50.0	Ø 1.97

	mm	inch
l	335.0	13.2
a	Ø 50.0	Ø 2.0

CONVERSION KITS

MATCHING ACCESSORIES

Dispenser Hook, Yellow Nozzles on pages 40–41