

RBM 385X

385 ML CARTRIDGE DISPENSER

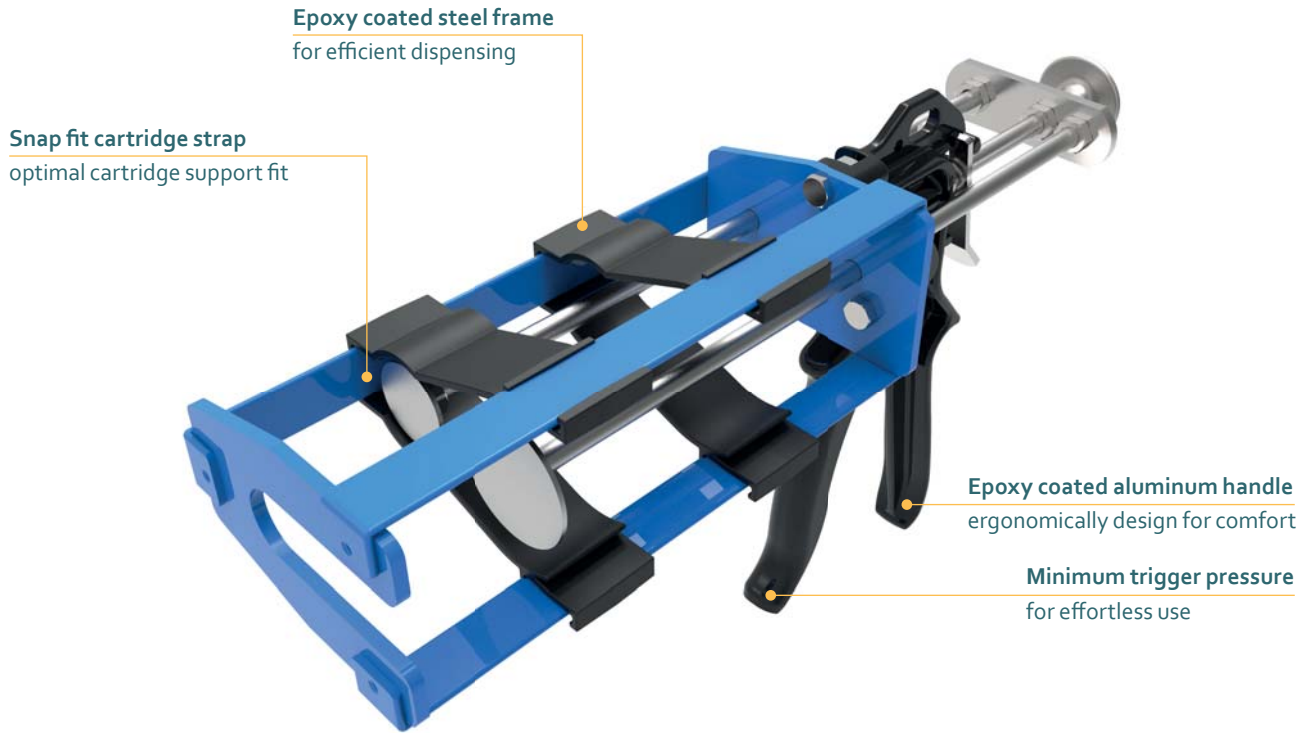

Model shown: RBM 385X 385 mL

FEATURES

- High quality cast aluminum handle
- Epoxy coated steel frame support
- Sintered alloy catch plate
- Snap fit cartridge strap
- Customization possible

BENEFITS

- For day long comfortable use
- For efficient dispensing
- Wear compensation device (WCD)
- For optimal cartridge support
- Customer labelling

APPLICATIONS



PRODUCT BY RANGE



THE RBM 385X 2-COMPONENT MANUAL DISPENSER HAS A HIGH-POWERED 25:1 MECHANISM DESIGNED FOR USE WITH HIGH VISCOSITY SEALANTS AND ADHESIVES.

SPECIFICATIONS

- Lightweight: 1.2 kg / 2.6 lbs
- Frame Length: 194 mm / 7.6 in
- Maximum Thrust: 3.5 kN
- Handle Material:
Epoxy Coated Aluminum
- Frame Material: Epoxy Coated Steel
- Tool Component Approvals: REACH
- Cartridge Capacity: 385 mL (13.6 oz)
- Cartridge Ratio: 3:1
- Mechanical Advantage Ratio: 25:1
- Viscosity: High
- Standard Color: Black/Blue
- Customized Versions: Yes

DIMENSIONS

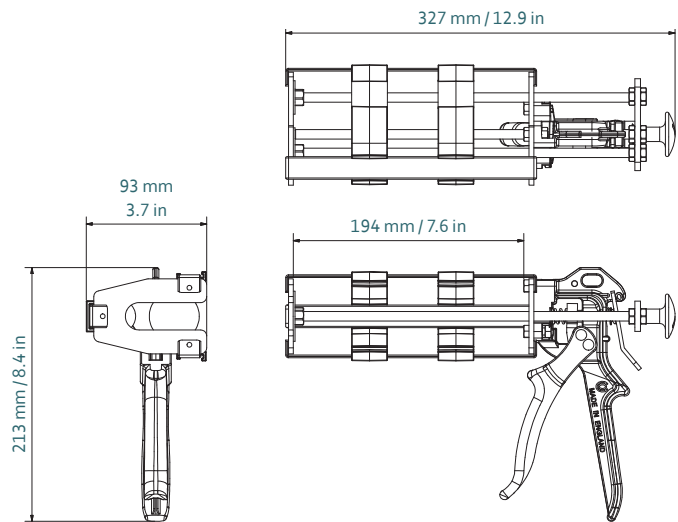

Part number	Article number	Packaging
DM2C 385-03-r25-001	177829	10 per Box

MATCHING MIXPAC™ SIDE-BY-SIDE CARTRIDGES

COMPATIBLE SIDE-BY-SIDE CARTRIDGES

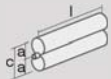

Plastic Cartridge
385 mL / 3:1 PP

3:1	mm	inch
l	171.0	6.73
a	Ø 54.4	Ø 2.14
b	Ø 32.6	Ø 1.28
c	90.0	3.54

CONVERSION KITS

MATCHING ACCESSORIES