

RBM 100

220 ML CARTRIDGE DISPENSER

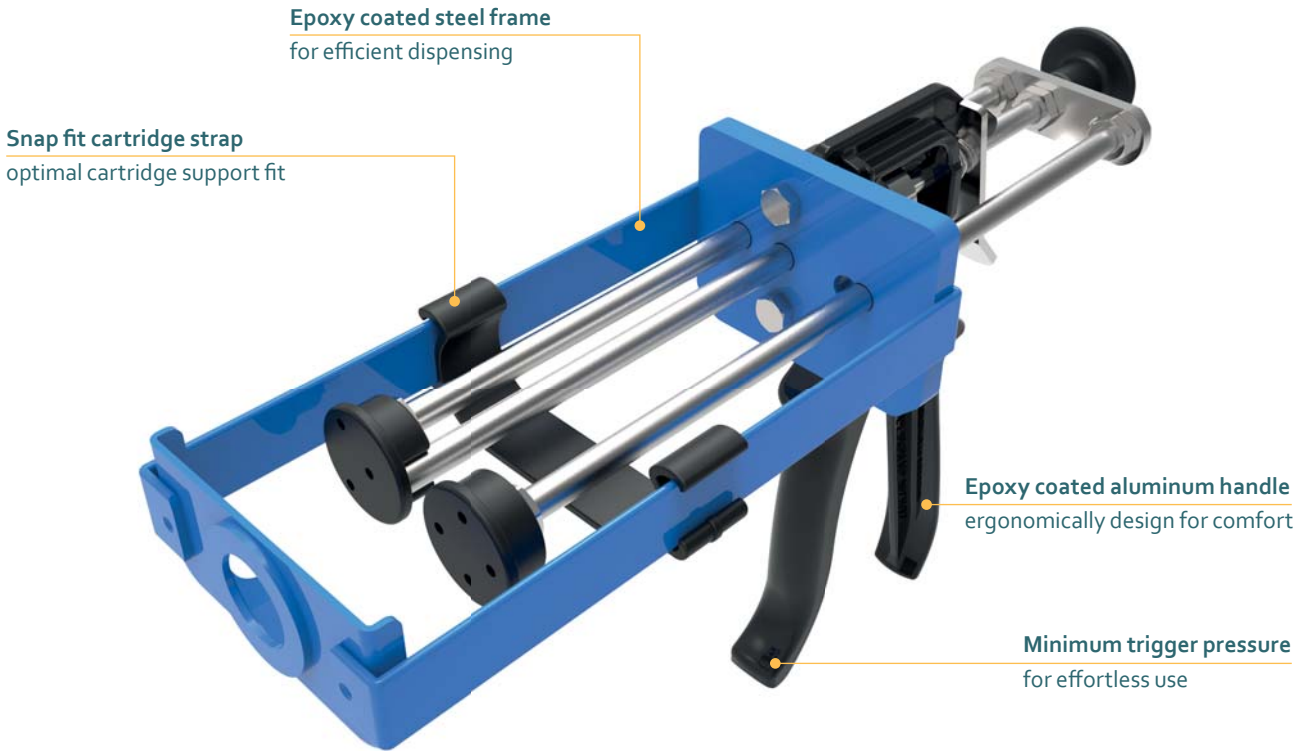

Model shown: RBM 100 220 mL

FEATURES

- High quality cast aluminum handle
- Epoxy coated steel frame support
- Sintered alloy catch plate
- Snap fit cartridge strap
- Customization possible

BENEFITS

- For day long comfortable use
- For efficient dispensing
- Wear compensation device (WCD)
- For optimal cartridge support
- Customer labelling

APPLICATIONS



PRODUCT BY RANGE



THE RBM 100 2-COMPONENT MANUAL DISPENSER HAS A HIGH-POWERED 18:1 MECHANISM WITH EPOXY COATED STEEL FRAME AND SNAP FIT CARTRIDGE STRAPS FOR OPTIMUM SUPPORT AND FIT.

SPECIFICATIONS

- Lightweight: 1.2 kg / 2.6 lbs
- Frame Length: 164 mm / 6.5 in
- Maximum Thrust: 3.5 kN
- Handle Material: Epoxy Coated Aluminum
- Frame Material: Epoxy Coated Steel
- Tool Component Approvals: REACH
- Cartridge Capacity: 220 mL (7.7 oz)
- Cartridge Ratio: 1:1
- Mechanical Advantage Ratio: 18:1
- Viscosity: Medium/High
- Standard Color: Black/Blue
- Customized Versions: Yes

DIMENSIONS

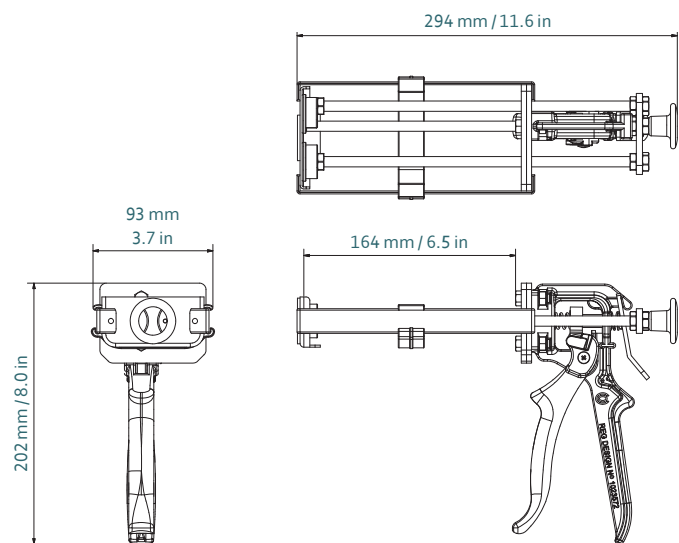

Part number	Article number	Packaging
DM2C 200-01-r18-201	177796	10 per Box

MATCHING MIXPAC™ CARTRIDGES

COMPATIBLE SIDE-BY-SIDE CARTRIDGES

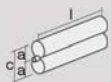

Plastic Cartridge
2×110 mL / 1:1 PE

1:1	mm	inch
l	144.0	5.67
a	Ø 37.0	Ø 1.46
c	76.0	2.99

CONVERSION KITS

MATCHING ACCESSORIES