

PPM 300 LV MR

450/600 ML CARTRIDGE DISPENSER

Epoxy coated steel frame
for efficient dispensing



Epoxy coated aluminum handle
ergonomically design for comfort

Minimum trigger pressure
for effortless use

Model shown: PPM 300 LV MR 600 mL

FEATURES

- High quality cast aluminum handle
- Epoxy coated steel frame support
- Sintered alloy catch plate
- Customization possible

BENEFITS

- For day long comfortable use
- For efficient dispensing
- Wear compensation Device (WCD)
- Customer labelling

APPLICATIONS



Bonding



Crack
Repair



Sealing



Water
Proofing



Solid
Surface

PRODUCT BY RANGE

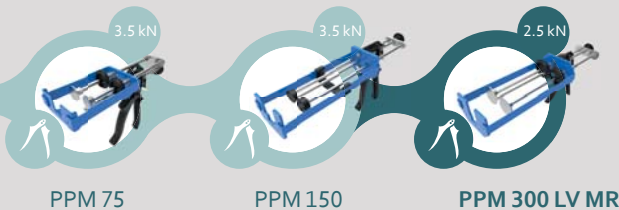

PPM 75

PPM 150

PPM 300 LV MR

THE PPM 300 LV MR 2-COMPONENT MANUAL DISPENSER OFFERS EFFICIENT DISPENSING WHILE THE WEAR COMPENSATION DEVICE GIVES THE DISPENSER A LONGER LIFE.

SPECIFICATIONS

- Lightweight: 1.7 kg / 3.7 lbs
- Frame Length: 240 mm / 9.4 in
- Maximum Thrust: 2.5 kN
- Handle Material: Epoxy Coated Aluminum
- Frame Material: Epoxy Coated Steel
- Tool Component Approvals: REACH
- Cartridge Capacity: 450 mL (15.8 oz)
- Cartridge Ratio: 1:1, 2:1
- Mechanical Advantage Ratio: 12:1
- Viscosity: Low/Medium
- Standard Color: Black/Blue
- Customized versions: Yes

DIMENSIONS

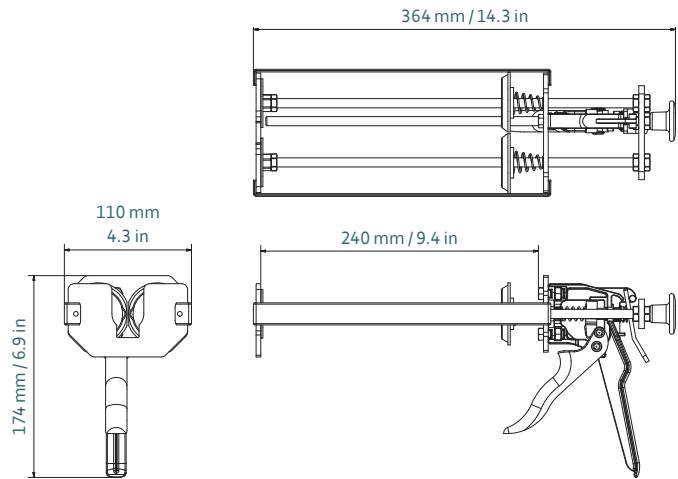

Part number	Article number	Packaging
M300 LV/2 (US)	-	1 per Box
M300 LV (US)	-	1 per Box

MATCHING MIXPAC™ CARTRIDGES

COMPATIBLE SIDE-BY-SIDE CARTRIDGES

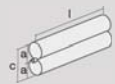

Plastic Cartridge
600 mL / 1:1 PP

1:1	mm	inch
l	217	8.54
a	Ø 48.0	Ø 1.89
c	95.5	3.76

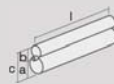

Plastic Cartridge
450 mL / 2:1 PP/PA

2:1	mm	inch
l	215.0	8.46
a	Ø 46.5	Ø 1.83
b	Ø 33.2	Ø 1.31
c	86.0	3.39

CONVERSION KITS

MATCHING ACCESSORIES