

# PPM 150

## 300 ML CARTRIDGE DISPENSER

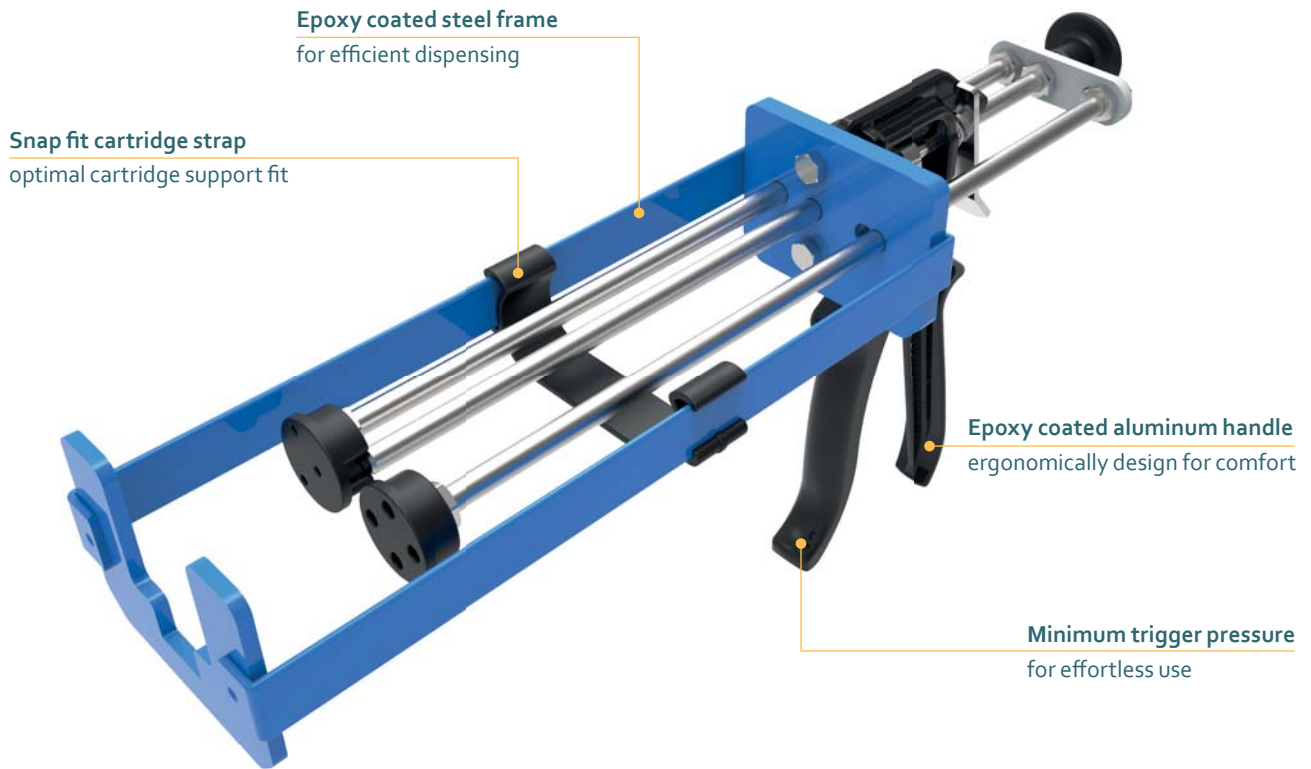

Model shown: PPM 150 300 mL

### FEATURES

- High quality cast aluminum handle
- Epoxy coated steel frame support
- Sintered alloy catch plate
- Snap fit cartridge strap
- Customization possible

### BENEFITS

- For day long comfortable use
- For efficient dispensing
- Wear compensation device (WCD)
- For optimal cartridge support
- Customer labelling

### APPLICATIONS



### PRODUCT BY RANGE

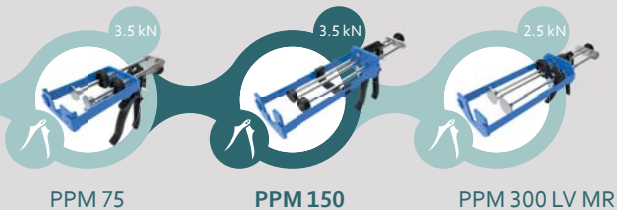

# THE PPM 150 2-COMPONENT MANUAL DISPENSER WITH 18:1 HIGH-POWERED MECHANISM AND SNAP FIT CARTRIDGE STRAPS FOR OPTIMAL CARTRIDGE SUPPORT AND FIT.

## SPECIFICATIONS

- Lightweight: 1.52 kg / 3.3 lbs
- Frame Length: 236 mm / 14.4 in
- Maximum Thrust: 3.5 kN
- Handle Material: epoxy Coated Aluminum
- Frame Material: Epoxy Coated Steel
- Tool Component Approvals: REACH
- Cartridge Capacity: 300 mL (10.5 oz)
- Cartridge Ratio: 1:1, 2:1
- Mechanical Advantage Ratio: 18:1
- Viscosity: Medium/High
- Standard Color: Black/Blue
- Customized Versions: Yes

## DIMENSIONS

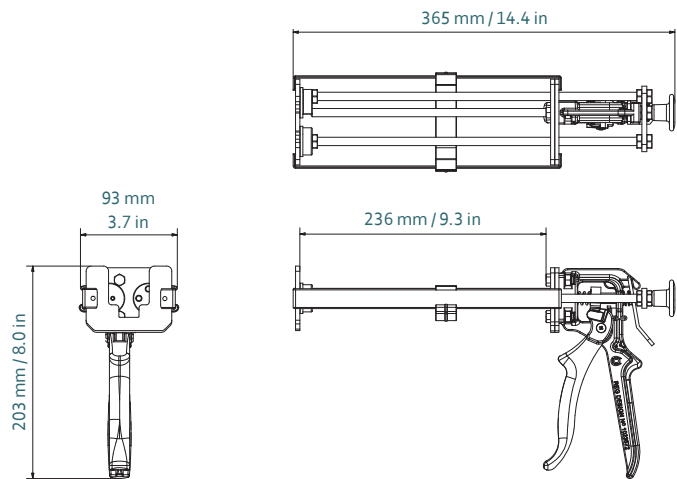

Part number	Article number	Packaging
DM2C 300-01-r18-001	167326 / M150 (US)	1 per Box

## MATCHING MIXPAC™ CARTRIDGES

## COMPATIBLE SIDE-BY-SIDE CARTRIDGES

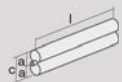

Plastic Cartridge  
300 mL / 1:1 PP

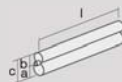

Plastic Cartridge  
225 mL / 2:1 PP

1:1	mm	inch
l	217	8.54
a	Ø 36.1	Ø 1.42
c	78.20	3.08

2:1	mm	inch
l	217.0	8.54
a	Ø 34.0	Ø 1.34
b	Ø 24.05	Ø 0.95
c	58.05	2.29

## CONVERSION KITS

Conversion kit included

## MATCHING ACCESSORIES

—