

H248 / H248 M

200 ML CARTRIDGE DISPENSER

Cartridge holder
in reinforced nylon



Trigger
integrated brake release

U-opening
cartridge snap fit

Model shown: H248 200 mL

FEATURES

- Anti-drip and trigger integrated brake release
- Life prolonging adjustment screw
- Reinforced nylon barrel housing
- High gearing ratio
- U-opening with cartridge snap fit
- Customization possible

BENEFITS

- Fast, reliable and clean application
- No loss of performance – anti-wear
- Long life technology
- Easy handling for precise working
- Easy insertion and removal of cartridges
- Customer labelling

APPLICATIONS



Chemical
Anchoring

PRODUCT BY RANGE



H248

H248 M

THE H248 2-COMPONENT MANUAL DISPENSER WITH REINFORCED U-OPENING BARREL AND HIGH GEARING RATIO OFFERS EASY HANDLING FOR PRECISE WORKING.

SPECIFICATIONS

- Lightweight: 0.82 kg / 1.8 lbs
- Cartridge Holder Length: 158 mm / 6.2 in
- Maximum Thrust: 3 kN (stroke 5 mm)
- Handle Material: Reinforced Nylon
- Cartridge Holder Material: Reinforced Nylon
- Cartridge Capacity: 200 mL (7 oz)
- Cartridge Ratio: 1:1
- Mechanical Advantage Ratio: 18:1
- Viscosity: Medium
- Standard Color: Black
- Customized versions on demand

DIMENSIONS

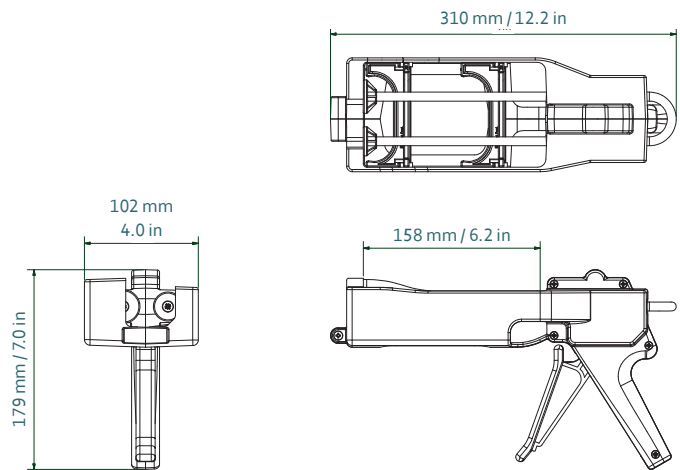

Part number	Article number	Packaging
DM2K 200-01-r18-201	154249 (H248) (For use with compatible cartridges)	10 per Box
DM2K 200-01-r18-101	151750 (H248M) (For use with MIXPAC cartridges)	10 per Box

MATCHING MIXPAC™ CARTRIDGES



C-System/F-System
200 mL / 1:1 PP/PA

COMPATIBLE SIDE-BY-SIDE CARTRIDGES

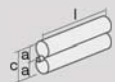

Plastic Cartridge
200 mL / 1:1 PP

1:1	mm	inch
l	148.0	5.83
a	Ø 37.0	Ø 1.46
c	79.0	3.11

CONVERSION KITS

MATCHING ACCESSORIES