

MIXPAC™ DM2X 400

400 ML CARTRIDGE DISPENSER

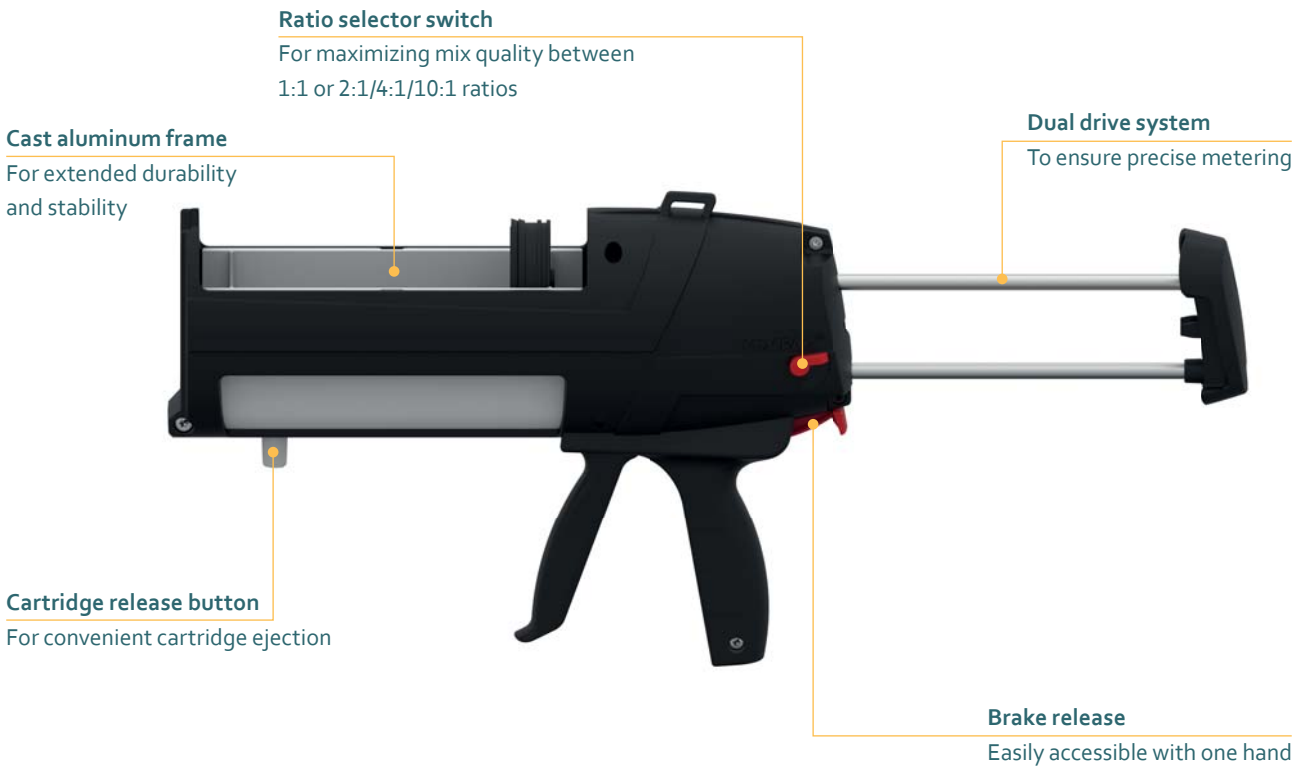

FEATURES

- Universal conversion kits with interchangeable cartridge trays and plungers
- High thrust ratio
- Ergonomically designed

BENEFITS

- Quick ratio exchange and use with DM2X and DP2X tools
- Easy to dispense high viscosity products
- Maximum comfort and fatigue-free operation

APPLICATIONS



PRODUCT BY RANGE

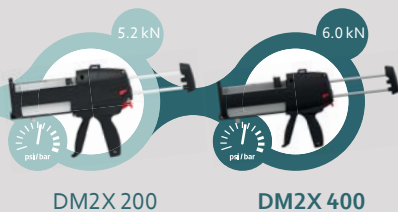

THE DM2X 400 IS A MANUAL DISPENSER FOR ACCURATE METERING WITH PRECISE AND CONSISTENT RESULTS.

SPECIFICATIONS

- Weight: 1.93 kg / 4.24 lbs
- Length: 366mm / 14.4 in
- Maximum thrust: 6.0 kN
- Thrust ratio: 35:1
- Tool material: cast aluminum
- Cartridge capacity: 400 mL
- Cartridge ratio: 1:1/2:1/4:1/10:1

DIMENSIONS

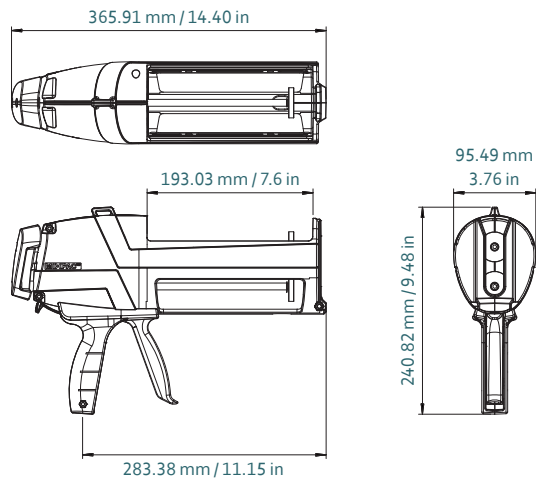

Part number	Article number	Ratio				Packaging
		1:1	2:1	4:1	10:1	
DM2X 400-01-60-01	165807	✓	✓			Packed individually 1 unit per master carton
DM2X 400-04-60-01	165808			✓		
DM2X 400-10-60-01	165809				✓	

MATCHING MIXPAC™ SIDE-BY-SIDE CARTRIDGES

C-SYSTEM / F-SYSTEM



C-System / F-System
400 mL / 1:1 PP/PA/PBT



C-System / F-System
400 mL / 2:1 PP/PA



C-System / F-System
400 mL / 4:1 PP/PBT



C-System / F-System
400 mL / 10:1 PP/PBT

CONVERSION KITS

CKX 400-01-01, CKX 400-04-01, CKX 400-10-01

MATCHING ACCESSORIES

All accessories are displayed on page 16.