

CCM 380

380 ML CARTRIDGE DISPENSER

Epoxy coated steel frame
for efficient dispensing



Epoxy coated aluminum handle
ergonomically design for comfort

Minimum trigger pressure
for effortless use

Model shown: CCM 380

FEATURES

- High power 18:1 mechanism
- Reduced risk of fatigue
- Compact coaxial frame
- Robust steel frame
- Customization possible

BENEFITS

- Less force required
- Increased productivity
- Higher volume for repetitive applications
- Locates cartridges securely to maintain ratios
- Customer labelling

APPLICATIONS



PRODUCT BY RANGE



THE CCM 380 IS A 2-COMPONENT MANUAL DISPENSER, ITS HIGH-POWERED 18:1 MECHANISM AND COMPACT COAXIAL FRAME ALLOWS FOR HIGHER VOLUME AND REPETITIVE APPLICATIONS.

SPECIFICATIONS

- Lightweight: 1.1 kg / 2.3 lbs
- Frame Length: 181 mm / 7.1 in
- Maximum Thrust: 3.5 kN
- Handle Material: Epoxy Coated Aluminum
- Frame Material: Epoxy Coated Steel
- Tool Component Approvals: REACH
- Cartridge Capacity: 380 mL (13.4 oz)
- Cartridge Ratio: 1:1, 2:1, 5:1, 10:1
- Mechanical Advantage Ratio: 18:1
- Viscosity: Medium/High
- Standard Color: Black/Blue
- Customized versions: Yes

DIMENSIONS

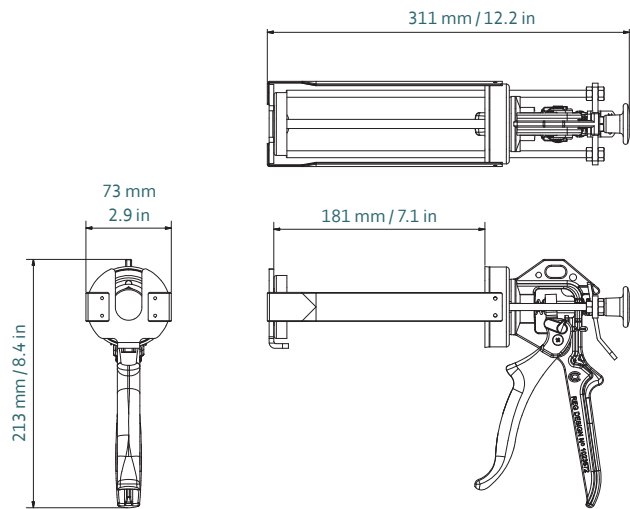

Part number	Article number	Packaging
DM2C 380-01-r18-001	178032 (1:1) / CCM 380-1 (US)	10 per Box
DM2C 380-02-r18-001	178035 (2:1) / CCM 380-2 (US)	10 per Box
DM2C 380-05-r18-001	178037 (5:1) / CCM 380-5 (US)	10 per Box
DM2C 380-10-r18-001	159903 (10:1) / CCM 380-10 (US)	10 per Box

MATCHING MIXPAC™ COAXIAL CARTRIDGES



Q-System Cartridge
380 mL 10:1 / PA

COMPATIBLE COAXIAL CARTRIDGES

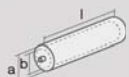

Plastic Cartridge
380 mL 1:1 / PP

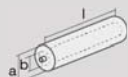

Plastic Cartridge
380 mL 2:1 / PP

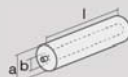

Plastic Cartridge
380 mL 5:1 / PP

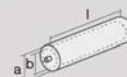

Plastic Cartridge
380 mL 10:1 / PP

	mm	inch
l	183.0	7.2
a	Ø 63.0	Ø 2.4
b	Ø 41.0	Ø 1.6

	mm	inch
l	183.0	7.2
a	Ø 63.0	Ø 2.4
b	Ø 33.5	Ø 1.3

	mm	inch
l	183.0	7.2
a	Ø 63.0	Ø 2.4
b	Ø 25.2	Ø 1.0

	mm	inch
l	183.0	7.2
a	Ø 63.0	Ø 2.4
b	Ø 18.0	Ø 0.7

CONVERSION KITS

MATCHING ACCESSORIES