

# CCM 310X

## 150/300/330 ML CARTRIDGE DISPENSER



Model shown: CCM 310X



### FEATURES

- High power 25:1 mechanism
- Reduced risk of fatigue
- Compact coaxial frame
- Robust steel frame
- Snap fit cartridge strap
- Customization possible

### BENEFITS

- Less force required, work comfortably for longer
- Increased productivity
- Higher volume for repetitive applications
- Locates cartridges securely to maintain ratios
- For optimal cartridge support
- Customer labelling

### APPLICATIONS

-  Bonding
-  Sealing
-  Water Proofing

### PRODUCT BY RANGE



# THE CCM 310X IS A 2-COMPONENT MANUAL DISPENSER, ITS HIGH-POWERED 25:1 MECHANISM AND COMPACT COAXIAL FRAME ALLOWS FOR HIGHER VOLUME AND REPETITIVE APPLICATIONS.

## SPECIFICATIONS

- Lightweight: 1.1 kg / 2.3 lbs
- Frame Length: 224 mm / 8.8 in
- Maximum Thrust: 4.5 kN
- Handle Material:  
Epoxy Coated Aluminum
- Frame Material: Epoxy Coated Steel
- Tool Component Approvals: REACH
- Cartridge Capacity: 150 mL (5.2 oz), 300 mL (10.5 oz), 330 mL (11.6 oz)
- Cartridge Ratio: 1:1, 10:1
- Mechanical Advantage Ratio: 25:1
- Viscosity: High
- Standard Color: Black/Blue
- Customized Versions: Yes

## DIMENSIONS

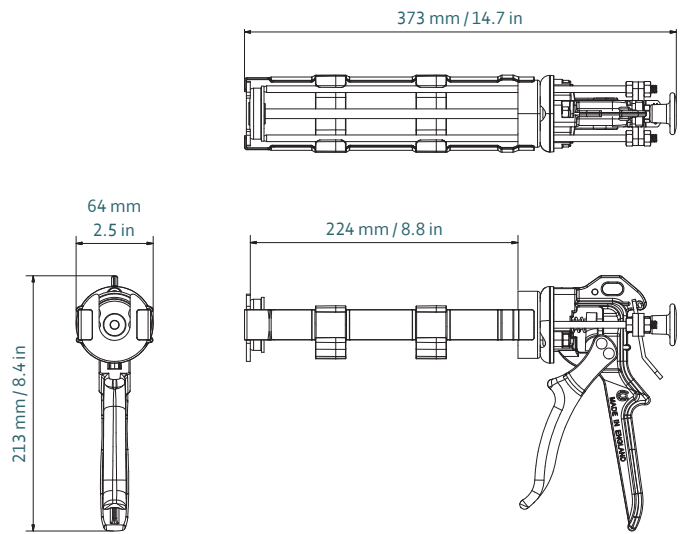

Part number	Article number	Packaging
DM2C 310-01-r25-001	178072 (1:1)	6 per Box
DM2C 310-10-r25-001	178075 (10:1)	5 per Box

## MATCHING MIXPAC™ COAXIAL CARTRIDGES

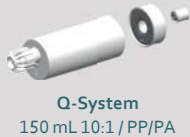

## COMPATIBLE COAXIAL CARTRIDGES

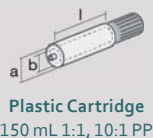

	mm	inch
l	117	4.6
a	∅ 50.0	∅ 1.9
1:1	b	∅ 32.0 ∅ 1.2
10:1	b	∅ 14.3 ∅ 0.5

	mm	inch
l	218.0	8.58
a	∅ 50.0	∅ 1.97
b	∅ 81.8	∅ 1.25

## CONVERSION KITS

## MATCHING ACCESSORIES