

B983 M

400 ML CARTRIDGE DISPENSER

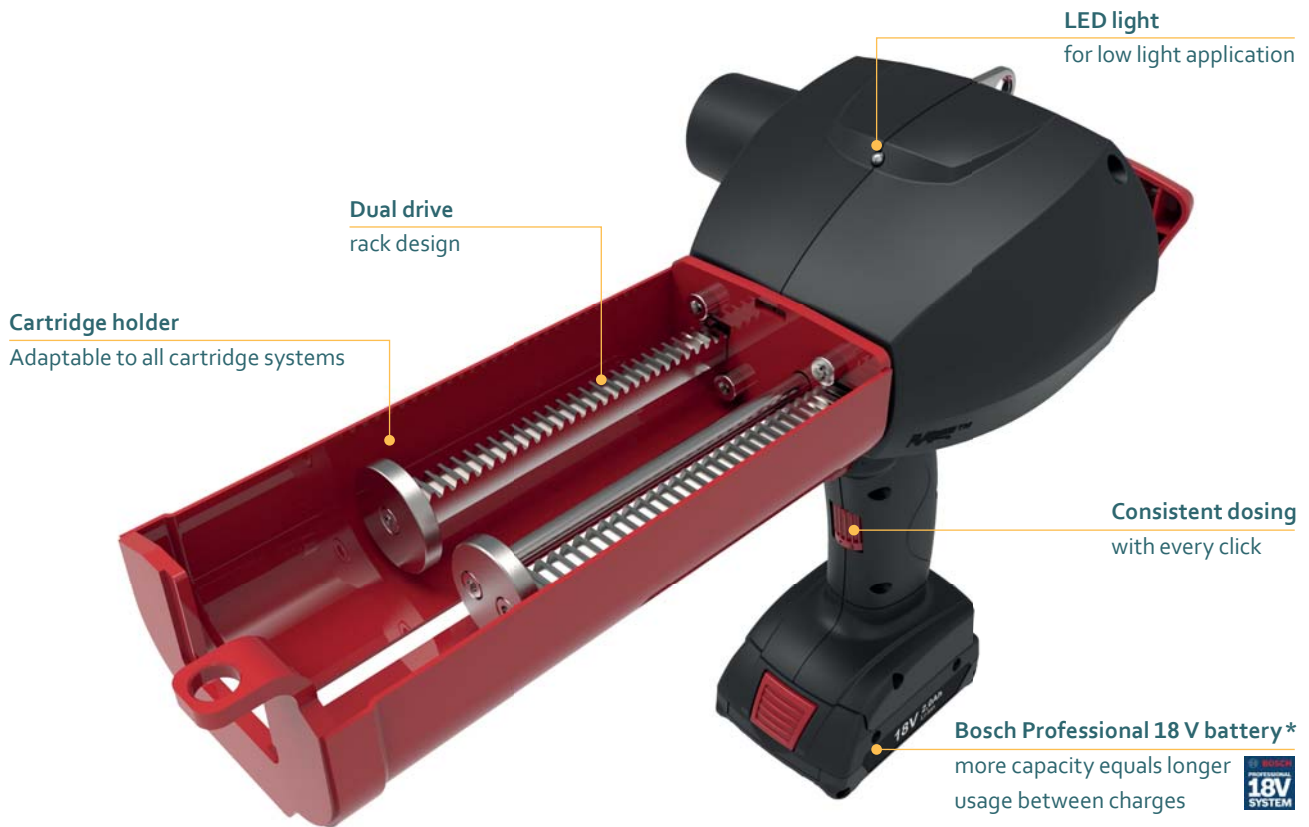

Model shown: B983 M 400 mL

FEATURES

- Unique memory function
- Dual drive rack design
- Anti-drip function
- 18 V Li-ion high performance battery
- U-opening with cartridge snap fit
- Customization possible

BENEFITS

- Consistent dosing with every click
- Reproduces quality of each adhesive
- Clean and efficient working
- Charge time: 65 min (100%)
- For easy insertion and removal of cartridges
- Customer labelling

APPLICATIONS

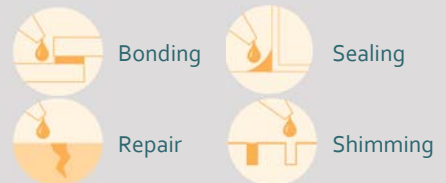

PRODUCT BY RANGE



THE B983 M 2-COMPONENT BATTERY DISPENSERS U-OPENING STEEL FRAME ALLOWS FOR EASY INSERTION AND REMOVAL OF CARTRIDGES, WHILE THE BOSCH PROFESSIONAL 18 V RECHARGEABLE BATTERY OFFERS LONGER USAGE BETWEEN CHARGES.

SPECIFICATIONS

- Weight: 3.5 kg / 7.7 lbs
- Cartridge Holder Length: 200 mm / 7.9 in
- Maximum Thrust: 5 kN (5 mm/s)
- Voltage: 18 V
- Battery Capacity: 2.0 Ah
- Battery Charge Time: 65 min (100%)
- Battery Type: Li-ion
- Handle Material: Reinforced Nylon
- Cartridge Holder Material: Steel
- Cartridge Capacity: 400 mL (14 oz)
- Cartridge Ratio: 1:1
- Viscosity: High
- Standard Color: Black/Red
- Customized versions on demand

DIMENSIONS

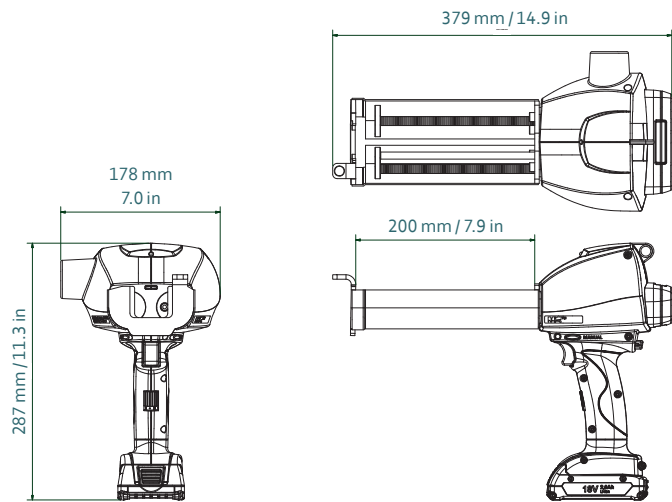

Part number	Article number	Packaging
DB2K 400-01-500-001	152603	1 per Box
DB2K 400-01-500-1US	152604 (US)	1 per Box

MATCHING MIXPAC™ SIDE-BY-SIDE CARTRIDGES

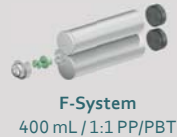
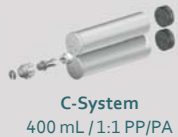

COMPATIBLE CARTRIDGES

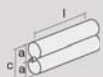

Plastic Cartridge
400 mL / 1:1 PP/PBT

1:1	mm	inch
l	185.0	7.28
a	Ø 45.0	Ø 1.77
c	93.0	3.66

CONVERSION KITS

–

MATCHING ACCESSORIES

Batteries and chargers on pages 90.