

B960 M

350 ML CARTRIDGE DISPENSER

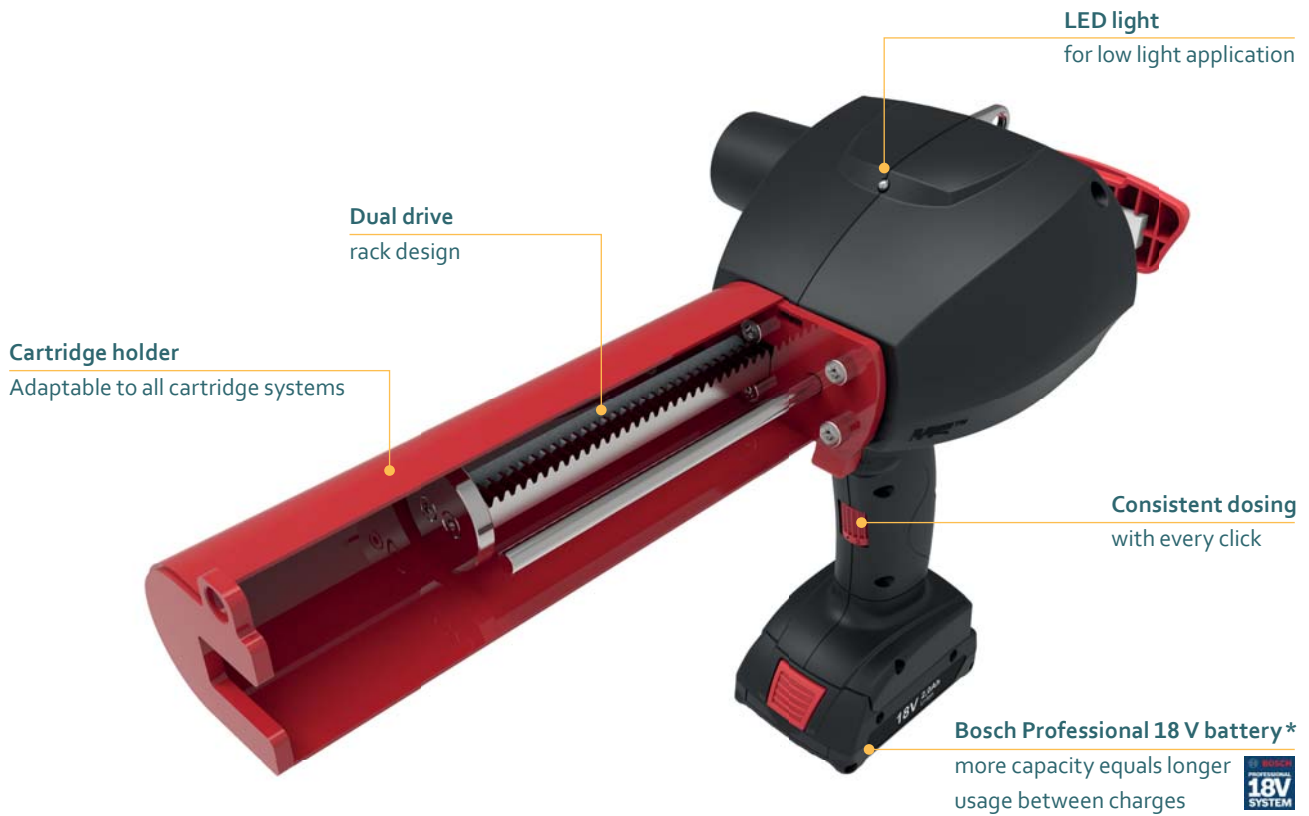

Model shown: B960 M 345 mL

FEATURES

- Unique memory function
- Dual drive rack design
- Anti-drip function
- 18 V Li-ion high performance battery
- U-opening with cartridge snap fit
- Customization possible

BENEFITS

- Consistent dosing with every click
- Reproduces quality of each adhesive
- Clean and efficient working
- Charge time: 65 min (100%)
- For easy insertion and removal of cartridges
- Customer labelling

APPLICATIONS



PRODUCT BY RANGE



B960 M

THE B960 M 2-COMPONENT BATTERY DISPENSER OFFERS CONSISTENT DOSING WITH EVERY CLICK, WHILE ACCIDENTAL MATERIAL DISCHARGE IS PREVENTED WITH THE BUILT-IN ANTI-DRIP MECHANISM.

SPECIFICATIONS

- Weight: 3.4 kg / 7.4 lbs
- Cartridge Holder Length: 232 mm / 9.1 in
- Maximum Thrust: 2.8 kN (5 mm/s)
- Voltage: 18 V
- Battery Capacity: 2.0 Ah
- Battery Charge Time: 65 min (100%)
- Battery Type: Li-ion
- Handle Material: Reinforced Nylon
- Cartridge Holder Material: Steel
- Cartridge Capacity: 350 mL (12.3 oz)
- Cartridge Ratio: 10:1
- Viscosity: Low/Medium
- Standard Color: Black/Red
- Customized versions on demand

DIMENSIONS

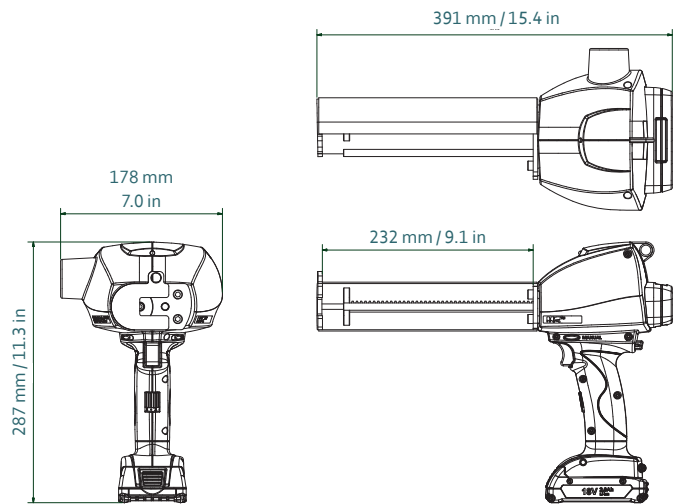

Part number	Article number	Packaging
DB2K 350-10-280-001	152602	1 per Box

MATCHING MIXPAC™ SIDE-BY-SIDE CARTRIDGES



J-System
350 mL / 10:1 PA

COMPATIBLE CARTRIDGES

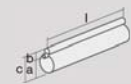

Plastic Cartridge
345 mL / 10:1 PP/PA

10:1	mm	inch
l	215.0	8.46
a	Ø 50.0	Ø 1.97
b	Ø 18.0	Ø 0.71
c	69.0	2.72

CONVERSION KITS

—

MATCHING ACCESSORIES

Batteries and chargers on pages 90.