

# B959 M

## 450 ML CARTRIDGE DISPENSER

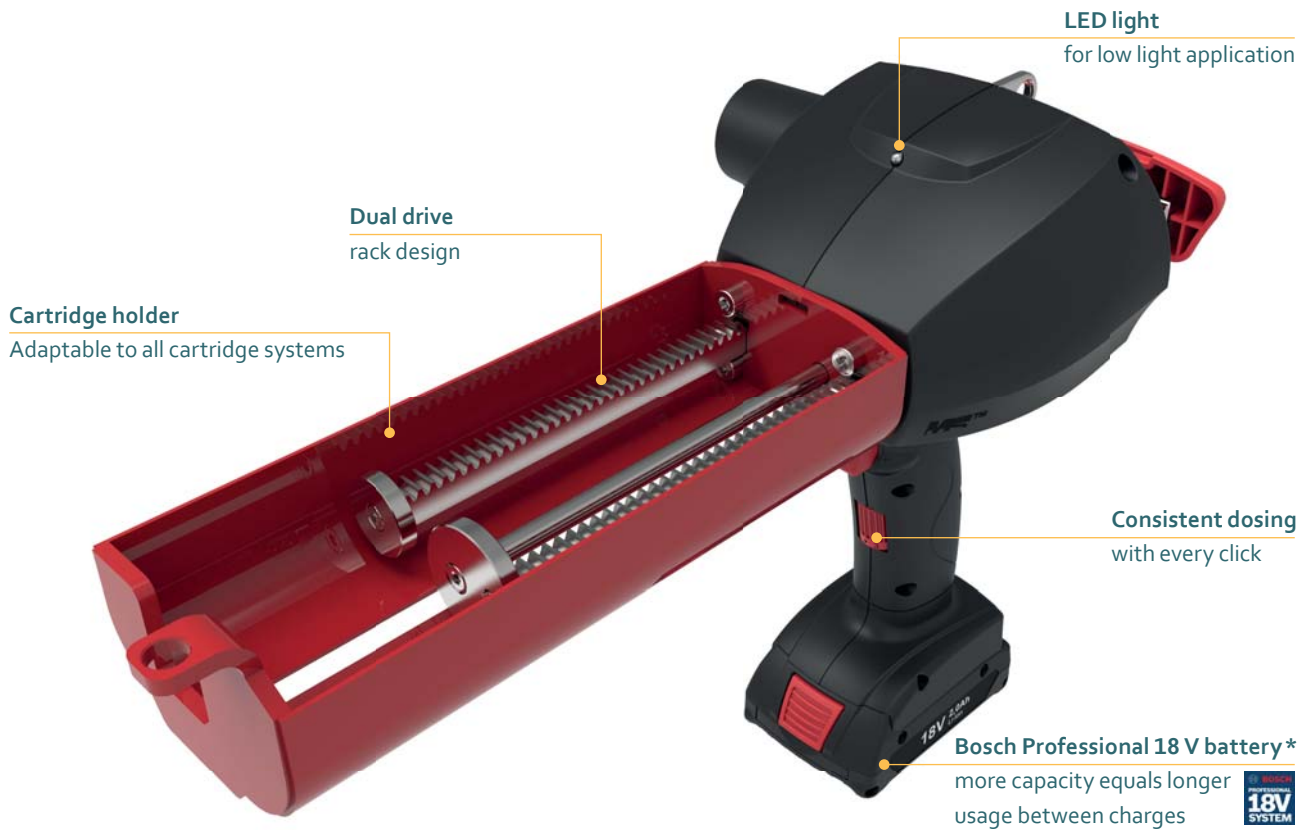

Model shown: B959 M 450 mL

### FEATURES

- Unique memory function
- Dual drive rack design
- Anti-drip function
- 18 V Li-ion high performance battery
- U-opening with cartridge snap fit
- Customization possible

### BENEFITS

- Consistent dosing with every click
- Reproduces quality of each adhesive
- Clean and efficient working
- Charge time: 65 min (100%)
- For easy insertion and removal of cartridges
- Customer labelling

### APPLICATIONS



### PRODUCT BY RANGE



B959 M

# THE B959 M 2-COMPONENT BATTERY DISPENSERS U-OPENING STEEL FRAME ALLOWS FOR EASY INSERTION AND REMOVAL OF CARTRIDGES, WHILE THE DUAL DRIVE RACK AND UNIQUE MEMORY FUNCTION REPRODUCES CONSISTENT DOSING EVERY TIME.

## SPECIFICATIONS

- Weight: 3.5 kg / 7.7 lbs
- Cartridge Holder Length: 229 mm / 9.0 in
- Maximum Thrust: 4.45 kN (5 mm/s)
- Voltage: 18 V
- Battery Capacity: 2.0 Ah
- Battery Charge Time: 65 min (100%)
- Battery Type: Li-ion
- Handle Material: Reinforced Nylon
- Cartridge Holder Material: Steel
- Cartridge Capacity: 450 mL (15.8 oz)
- Cartridge Ratio: 2:1
- Viscosity: Low/Medium
- Standard Color: Black/Red
- Customized versions on demand

## DIMENSIONS

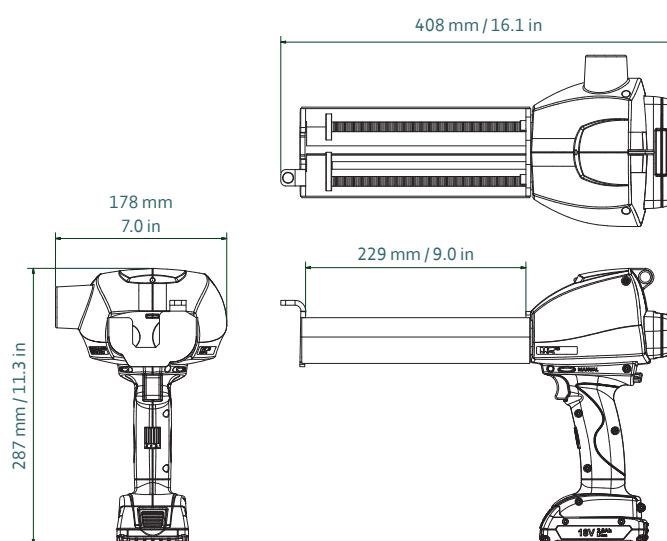

Part number	Article number	Packaging
DB2K 450-02-445-101	152611	1 per Box
DB2K 450-02-445-1US	152612 (US)	1 per Box

## MATCHING MIXPAC™ COAXIAL CARTRIDGES



**J-System**  
450 mL / 2:1 PA/PP

## COMPATIBLE CARTRIDGES

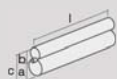

**Plastic Cartridge**  
450 mL / 2:1 PP/PA

2:1	mm	inch
l	215.0	8.46
a	Ø 49.5	Ø 1.95
b	Ø 36.2	Ø 1.43
c	86.0	3.39

## CONVERSION KITS

—

## MATCHING ACCESSORIES

Batteries and chargers on pages 90.