

AIRFLOW™ 1 VBA 200A

400 ML CARTRIDGE DISPENSER

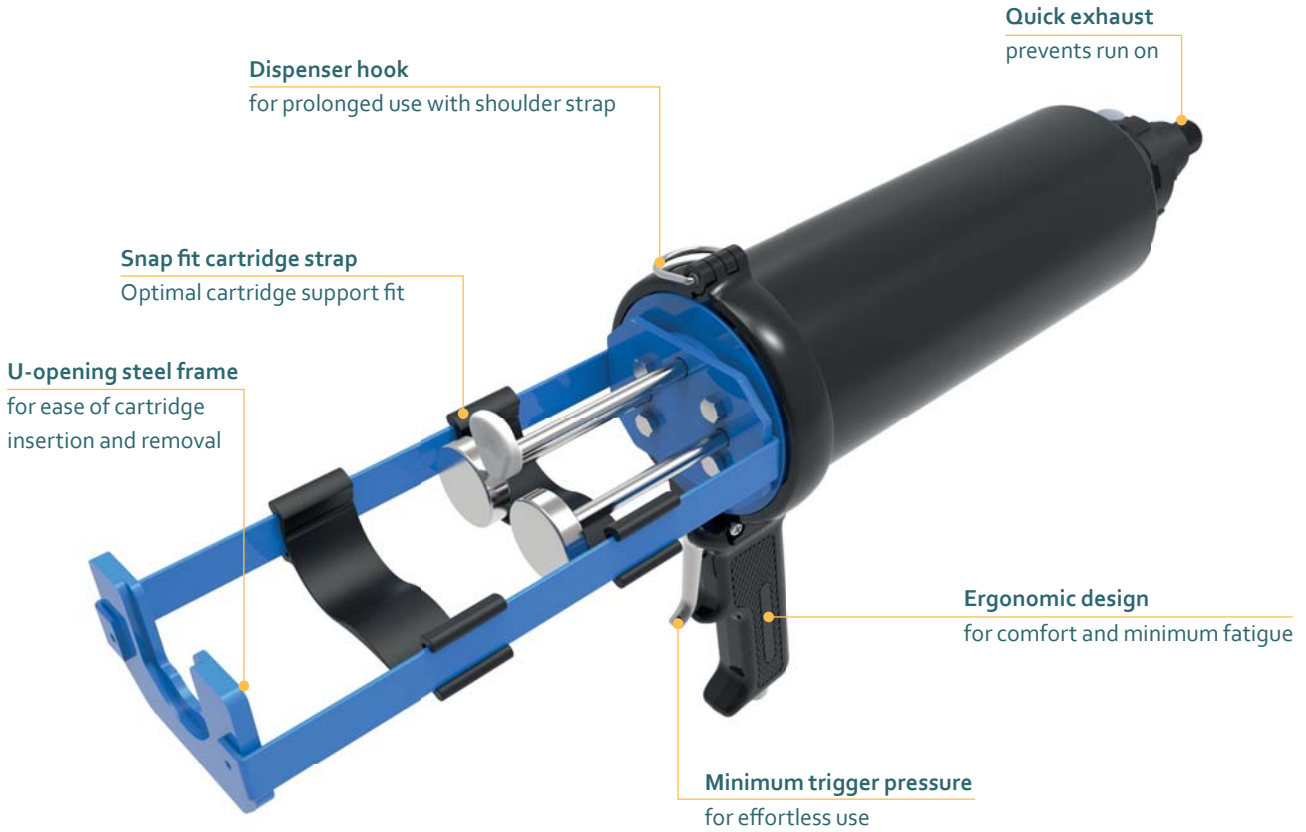

Model shown: AirFlow 1 VBA 200A 400 mL

FEATURES

- Air return as standard
- Minimum trigger pressure
- Snap fit cartridge strap
- Quick exhaust valve
- Customization possible

BENEFITS

- Fast, accurate and effortless application
- For effortless use and minimum fatigue
- For optimal cartridge support
- Prevents run-on
- Customer labelling

APPLICATIONS



PRODUCT BY RANGE



THE AIRFLOW 1 VBA 200A 2-COMPONENT PNEUMATIC DISPENSER HAS AIR RETURN AS STANDARD WHILE THE U-OPENING STEEL FRAME AND CARTRIDGE STRAPS ALLOWS FOR EASY INSERTION AND SUPPORT OF CARTRIDGES.

SPECIFICATIONS

- Weight: 2.93 kg / 6.4 lbs
- Frame Length: 216 mm / 8.6 in
- Maximum Thrust: 5.0 kN
- Maximum Pneumatic Pressure: 6.8 bar / 100 psi
- Air Consumption: 40 litres/min
- Handle Material: Aluminum
- Frame Material: Steel
- Tool Component Approvals: CE, REACH
- Cartridge Capacity: 400 mL (14 oz)
- Cartridge Ratio: 1:1
- Viscosity: Medium/High
- Standard Color: Black/Blue
- Customized versions on demand

DIMENSIONS

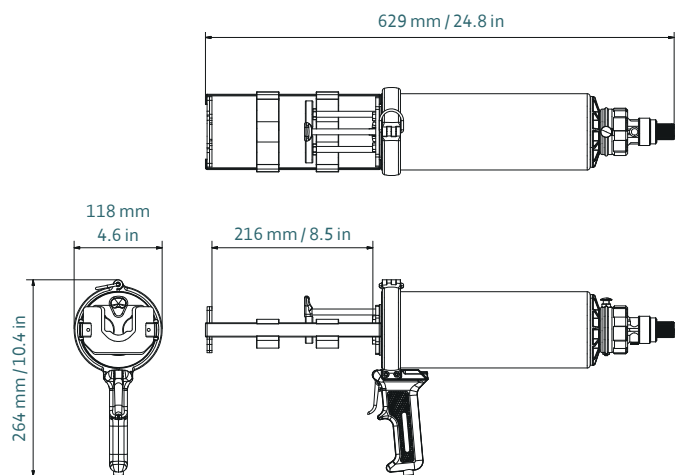

Part number	Article number	Packaging
DP2C 400-01-500-111	177775	1 per Box

MATCHING MIXPAC™ CARTRIDGES



C-System/F-System
400 mL / 1:1 PP/PA/PBT

COMPATIBLE SIDE-BY-SIDE CARTRIDGES

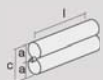

Plastic Cartridge
400 mL / 1:1 PP/PBT

1:1	mm	inch
l	185.0	7.28
a	Ø 45.0	Ø 1.77
c	93.0	3.66

CONVERSION KITS

MATCHING ACCESSORIES